



User's manual DH96 - FT



Chapter 1	Page
Product description	
Introduction	2-3
Technical specifications	4-5
Safety warnings	6
Chapter 2	
Installation and startup	
Dimensions	7
Wiring diagrams	8-9
Input configuration	10-11
Plugin cards	12
Modification of the auxiliary supply	13
Chapter 3	
Setting up the instrument	
Keyboard functions	14
Setup introduccion	15
Frequencymeter configuration	16-17
Tachometer configuration	18-19
Chapter 4	
Programmable digital Instruments	
DH96´s serie	20-21
Annotations	22

The new DH96 FT performs functions of frequencymeter by measuring the pulses per second of the input signal; and functions of tachometer for measurement of r.p.m. and speeds in diverse engineering units.

This DH 96 FT instrument is equipped with a 5 digit red display. Parameters of the instrument are user-programmable by means of four frontal keys.

The instrument permits to save peak and valley values into and internal EEPROM memory. This storage process is even performed in case of power supply failure of the instrument.

The instrument also saves the visualized value into a NON VOLATILE RAM memory, this voiding inconveniences of systems with batteries.

The choice of the input transducer type is done through several on-board micro-dips.

The easy and intuitive setup process of digital indicators enables the user to quickly familiarize with their operation mode, for the modification of diverse configuration options with no need to consult this manual again.

Instruments of the DH 96 Series have been tested in laboratories and checked in industrial environments, and have successfully passed the most rigorous tests involving ambient conditions, electrical noises, electromagnetic disturbances, mechanical vibrations, etc...

Expansion options

The instrument standard features can be expanded with the use of optional pluggable cards, in order to meet particular requirements.

Available optional cards are:

- Cards equipped with two alarm.
- Cards equipped with four alarm.
- Cards equipped with analog output.
- RS-485 communications.
- RS-232 communications.
(Modbus-Protocol)

The instrument is equipped with a connector for the card input.

Card equipped with two alarm relay outputs

- Trip due to maximum or minimum conditions.
- Trip delay user-configurable between 1 and 9999s.
- Reset delay user-configurable between 1 and 9999s.
- Hysteresis user-configurable between 1 to 9999 points.
- Optional trip latch.
- Optional operation mode with failure safety function.



Card equipped with two alarm relay outputs

- Trip due to maximum or minimum conditions.
- Trip delay user-configurable between 1 and 9999s.
- Reset delay user-configurable between 1 and 9999s.
- Hysteresis user-configurable between 1 to 9999 points.
- Optional trip latch.
- Optional operation mode with failure safety function.



Cards equipped with analog output.

- User-configurable range output.
- 0-20mA / 4-20mA
- 0-10V / 2-10V



Cards equipped with RS-485 or RS-232 serial communication output.

- MOD BUS communication protocol.
- User-configurable instrument direction.
- User-selectable baud rate.
- User-selectable parity and stop bits.



Technical specifications

Auxiliary supply

Rated value:	115 V o 230 V (-15%, +20%)
Frequency range:	45 a 65 Hz
Burden:	4 VA (without optional card) 7 VA (maximun burden)

Display

99999
7 segments
14 mm high 5 digits
Hi-efficacy red colour
Overrange indication: "----"
2 leds alarm indication
Programmable decimal point
Data updating time on disp. 100 ms

Input circuit

High Voltage:	Meas. System by means of a microp.
NamurSensor:	30 a 600 Va.c.
Rc	
loff	1 KOhm
Ion	< 1mA d.c.
NPN Y PNP Sensor:	> 2,2 mA d.c.
Rc	
Logic Level 0	1 kOhm
Logic Level 1	< 2,4 V
Free Contact:	> 2,6 V
Vc	
Rc	5V
Fc	3,9 kOhm

Analog output

Output types:	100 Hz
	0 ... 20 mA or 4 ... 20 mA
Output impedance:	0 ... 10 V or 2 ... 10 V
Response time:	< 500 Ω
Ripple - RMS:	< 150 ms
Accuracy class:	< 0,1 %
Temperature coefficient:	0,2

Isolation

Between the input circuit, the measuring circuit and the output (relays analog, Rs485 or RS232

Test voltage:

Pulse test:	3 kV RMS 50 Hz during 1 min 4 kV (1.2 / 50 μ s)
-------------	--

Environmental conditions

Storage temperature :	-40 °C ... + 70 °C
Operation temperature:	-10 °C ... + 65 °C:

Relays characteristics **1 change over contact**

Rated a.c. current:	8 A
Maximun a.c. current:	10 A
Rated voltage:	250 V a.c. 50 Hz
Maximun voltage (VDE 0435):	440 V a.c.
Maximun a.c. Resistive load:	2000 VA
Isolation resistance at 500V:	> 10 ⁴ MΩ
Contact-coil isolation:	6000 V a.c.
Contact-contact isolation :	1000 V a.c.
Mechanical endurance:	> 20 x 10 ⁶ operations
Electrical endurance:	> 2 x 10 ⁶ operations

Relays characteristics **1 single contact**

Rated a.c. current:	5 A
Maximun a.c. current:	5 A
Rated voltage:	250 V a.c. 50 Hz
Isolation resistance at 500V:	> 1000 MΩ
Contact-coil isolation:	2000 V a.c - 1 min
Contact-contac isolation:	1000 V a.c. - 1 min
Mechanical endurance:	> 20 x 10 ⁶ operations
Electrical endurance:	> 100 x 10 ³ operations

General characteristics

Dimensions:	96 x 48 x 138 mm
Weight:	550 g
Case material:	Self-exting ABS,anthracite grey
Protection degree:	Frontal: IP54 IP 65 with frontal protec.
	Case: IP20
	Terminal: IP20

Desing standards

IEC 1010
IEC 348
IEC 664
IEC 801
EN 50081-2
EN 50082-2

17.3 Information and warning texts.

The DH96 meets protection class I.

- All indicators are equipped with a grounding terminal.
- The case is not dangerous to tactile touching (isolating material).
- Screws of terminals are not accessible for human appendix.

This instrument has been designed and tested to meet IEC348 standard and is factory-shaped in proper conditions. The manual you hold in your hands contains information and warnings that the user should respect in order to guarantee a proper operation of all instrument's functions and keep its safety conditions.

17.3.2 Installation.

The instrument is for indoor use. It could be occasionally subjected to temperatures between +75°C and -10°C keeping its safety conditions.

The instrument must not be powered and used until to be correctly assembly on the board. Before powering the instrument, its grounding terminal must be connected to a suitable protection conductor.

17.3.4 Warning!

Any interruption of the protection conductor, either inside or outside the instrument, or the disconnection of the protection grounding terminal might imply a dangerous situation; therefore, any intentional interruption is totally forbidden.

17.3.5 Adjustment, element replacement and repairing actions.

With the instrument powered on, the terminals could be dangerous to touch and cover opening actions may allow accessing dangerous parts. Therefore, before any adjustment, replacement, maintenance or repairing operation is carried out, the instrument must be disconnected from any power supply source.

No adjustment, maintenance or repairing operation should be done over the instrument open and powered and, should those are essential, high-qualified operators must perform them.

Check that fuses used for replacing damaged ones match required types and rated currents. The use of improvised fuses or to short-circuit fuse bases is totally avoided.

17.3.6 Defects and malfunction.

When any protection failure is suspected to exist, the instrument must be immediately put out of service. The protection could be damaged whether:

- You can see damages on the case
- It cannot perform proper measurements.
- Storage conditions were not the suitable ones.
- Any damage in transit occurred.

Holding piece

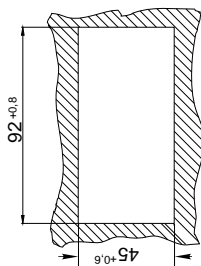
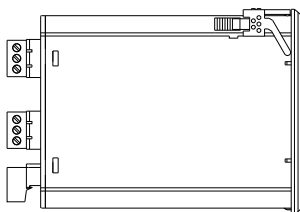
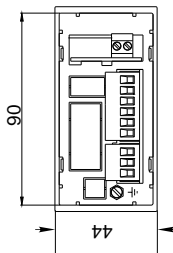
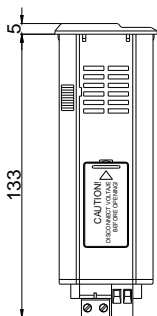
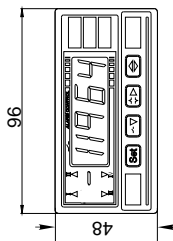
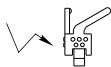

Panel cut-out

INPUTS DESCRIPTION

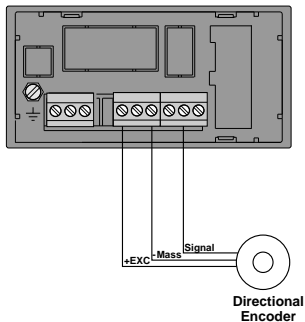
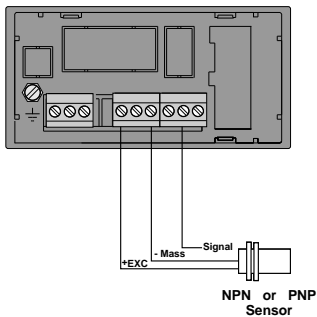
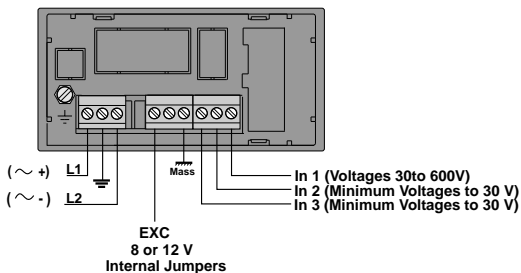

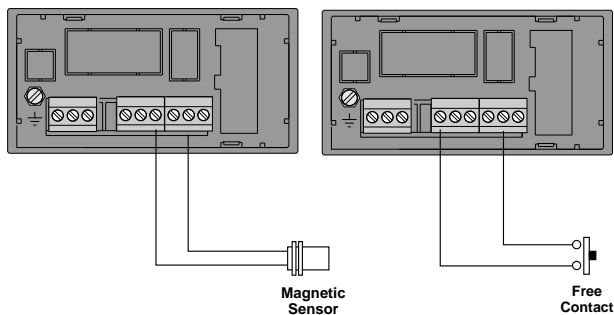
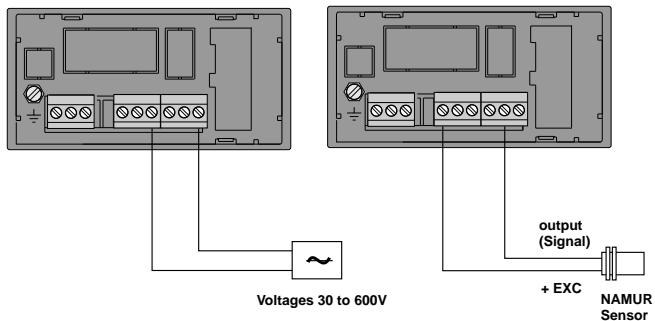

Setting the input

The DH96 FT digital indicator permits several types of transducers to be used for measuring the input signal.

The transducer type will be selected by means of the on-board microswitches, SW. For accessing these microswitches the box must be opened according to indications in the page 12.

Once these microswitches have been located, select the transducer to be used just following indications attached in the page 11.

Note:

The instrument is factory shipped for the use of a input voltage to 660 Va.c.

The microswitch number 3 acts over a low-pass filter that filters signals exceeding 5500 Hz. For measuring signals higher than this frequency, this microswitch must be disabled (off).

Transducer power supply

The instrument delivers an auxiliary voltage of 8V (stabilized) and 12V (no stabilized) for power supplying the transducers.

To select the type of required power supply mode, the instrument is equipped with a jumper Jp1, that delivers two positions, as the attached figure shows.

In case that the used transducer requires power supply different from the available in the instrument, the auxiliary power supply source for DIN rail mounting, FM 45, can then be utilized. This source delivers an auxiliary voltage user-selectable by means of some internal jumpers with an easy access. Available output voltages delivered by this source are: 5,10 or 15V (stabilized), or 24 V(no Stabilized). Insulation voltage of this source is of 3KV.

Input sensor selection

Sw1	1	2	3	4	5	6	7	8	9	10
Voltage to 660 V	off	off	on	off	off	off	off	off	on	off
NAMUR Sensor	on	off	on	on	off	off	off	off	on	off
Magnetic Sensor	off	off	on	off	off	off	off	off	on	off
NPN Sensor	on	on	off	off	off	off	off	off	on	off
PNP Sensor	on	off	off	on	off	off	off	off	on	off
TTL / 24 V	on	off	off	off	on	off	off	off	on	off

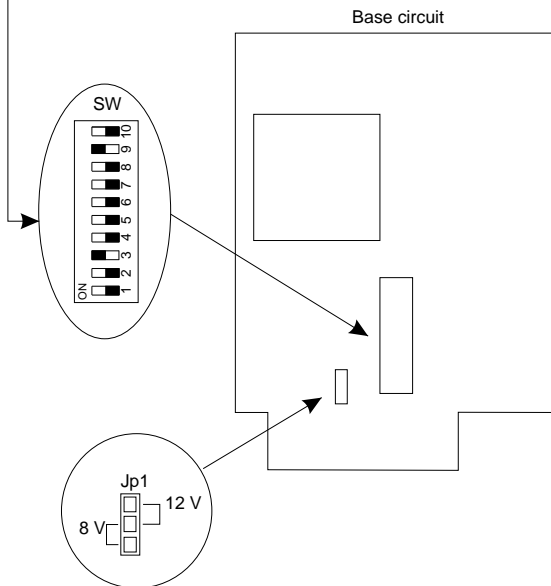

Plugging cards

WARNING: Insure that no incoming wire is connected to the instrument before doing any work on the equipment, since failure to observe this practice can result in equipment damage and even serious injury.

Proceed as below pictures show:

1) Press the case holding piece with a screwdriver or a similar tool in order to release the base from the reset of the case.

2) Remove the set composed by the base and circuits by pulling the base and carefully sliding it out.

3) Insert the card into the appropriate connector. Take care that only the connector is press but not all the card.

4) Put the set composed by the base and circuits in again by pushing the base and carefully sliding it into. When the set is totally inserted, press until the case holding pieces are fitted into the pertinent holes.



Instrument is manufactures to be energized at 230 V a.c.. But it is possible to change to 115 V a.c.. Following the instructions below mentioned.

To perform this modification, open the instrument case (see page 12, “ Plugging cards “), thoughfully following all safety warninigs (see section 17.3.5 at page 6), and identify the zone referred in the figure 1.

For an auxiliary supply of 230 V only the jump labeled as 1 mus be done (figure 2).

On the contrary, if an auxiliary supply of 115 V is required, only jumps labeled as 2 and 3 must be done (figure 3).



Figure 1



Figure 2



Figure 3

Setup option



Pressing this key, setup menus are accessed for user-configuration actions. Once within the setup menus, use this key to validate the options and modifications.

Peak and Valley



Pressing this key the maximum and minimum values monitored are displayed. Both values are automatically updated and stored in the instrument's EEPROM memory. To delete the peak or valley value just press this key during 3 s. While the value is on screen. To exit this function press again .

Default setup values



Pressing this key during at least 5s, default setup values replace user-configured ones.

Alarms



(Only in case that the instrument is equipped with any alarm card).

By pressing this key the alarm condition value can be visualized and modified (provided modification actions are enabled). Pressing then the button once again, the condition for the alarm 1 is shown by display, and can even be modified whether the CE condition of the alarm is enabled.

Password



Pressing simultaneously both keys when the instrument is powered on, a 4 digit password can be set in order to control the access configuration options. To disable this password, reset the instrument and simultaneously press again both keys when powering it. Enter the set password and menus will be accessible again.

Note: The password must be always entered twice, the first one to define it and the second one to confirm it. In case that the confirmation does not match with the first defined password, instrument will continue its initialization process.

Besides, the DH 96 FT offers another security level against parameter modification. That way, the section CE, with options Yes or Not, is shown at the end of any menu group.

In the case that, for instance, along the configuration of all the instrument's parameters, the option CE has been always set at NO, no parameter will be allowed to be modified when entering again into the setup unless this option is reached and set at YES.

The DH 96 FT configuration can be carried out in following a very simple and intuitive procedure.

The complete instrument configuration can be carried out in a logical mode through a tree-type menu.

Steps to be followed are :

1) Select the instrument function, that is, tachometer or frequencymeter operation mode.

2) Proceed to the instrument configuration through the menu options that will be enabled according to previous selection of the operation mode.

- When the instrument is set for operation as a frequencymeter, the user can define the position of the decimal point, the number of averaging operations to be done for filtering the input signal, and the measuring limit time to fix the waiting time for an input pulse to occur before the instrument considers a frequency zero readout to be measured.

-When the instrument is set for operation as a tachometer, the user can define the measuring mode, direct or inverse; the turn-pulse ratio, and set the readout in display by the option (RATE); besides, as for the case of the frequencymeter, the number of averaging operations and the measuring limit time to fix the waiting time before the instrument considers a null input to be occurred.

Function Selection

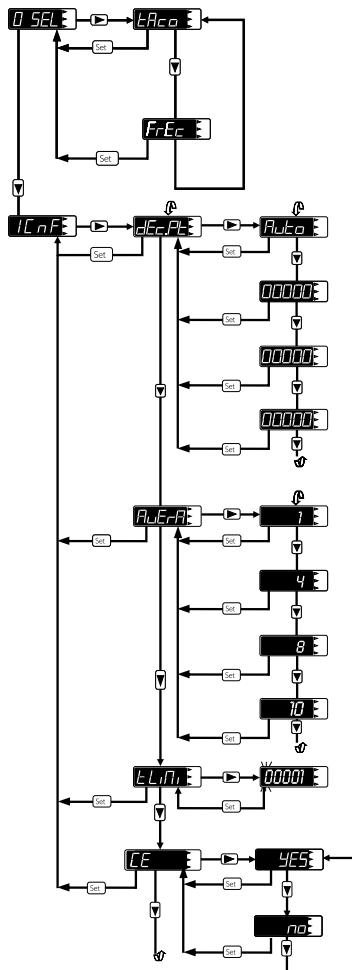

Setting the instrument for frequencymeter operation

1.- Function selection.



Select here the desired instrument function. For a tachometer operation set (Taco) and for frequencymeter operation set (Frec).

2.- Menu for setting the instrument for frequencymeter operation.

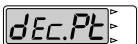

Set the position of the decimal point, that can be fixed or in automatic mode. For this last option, the instrument will show the number of decimals in dependence on the displayed frequency readout, so that, when the frequency is below 100 Hz, two decimals appear by display; for a frequency from 100 Hz to 1000 Hz, then only one decimal is displayed; and, finally, when the frequency exceeds 1000 Hz, no decimal can be read in display.



For a unsteady measured signal, several measurements can be taken in order to get a much more stable final readout.



The measuring limit waiting time can be set from 1 to 10s. This time is used to limit the waiting time between two successive incoming pulses. Whether no pulse is received during the set limit time, the displays shows a zero readout.

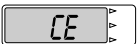

Set at (NO) any modification of the above parameters is avoided. Set at (YES) their modification is then enabled.

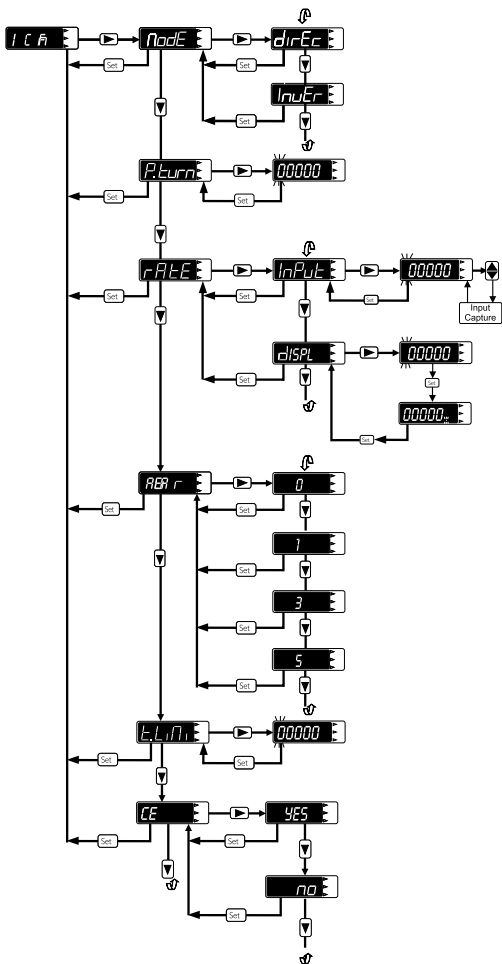

Setting the instrument for tachometer operation

3.- Menu for setting the instrument for Tachometer operation.

Mode

Set the operation mode, that is, direct or inverse mode. The instrument will operate in direct mode (direc) when the readout in display is directly proportional to the input frequency. The inverse mode operation (inver) will be used when the variation of the readout in display is inversely proportional to the input frequency, that is, a higher frequency means a lower readout value.

P.turn

The second parameter to be set is the turn-pulse ratio of the input signal. For instance, in case of a cog wheel with 30 cogs, this parameter must be set to 30.

rate

Following, set the value to be displayed in relation to the measured t.p.m.. For instance, in case of a carrying belt with a 20 cm axis and turning at 150 t.p.m., the speed of the carrying belt would be :

$$\frac{\text{r.p.m} \times \pi \times d^{(m)}}{60} = \frac{150 \times \pi \times 0.20\text{m}}{60} = 1.571 \text{ m/s}$$

Set the axis t.p.m. at INPUT option; 150 t.p.m. For the case of the example.

Set the forward speed of the carrying belt at displ option; 1.571 for the case of the example. Set firstly the value 1571 and then set the decimal point to the proper position.

In case of a unsteady incoming signal, several measurements can be taken in order to get a much more stable final readout.

A.E.A r

The measuring limit waiting time can be set from 1 to 10s. This time is used to limit the waiting time between two successive incoming pulses. Whether no pulse is received during the set limit time, the displays shows a zero readout.

E. 1. 0. 1

Set at (NO) any modification of the above parameters is avoided. Set at (YES) their modification is then enabled.

ce

Digital series

DH96

Presents full range of digital panel instruments with high performance

- Fully programmable.
- High performance.
- Easy to use.
- Strong desing.



- 2 relay card.
- 4 relay card.
- Analog output card
- RS232 y Rs485 communications

Programmable digital instruments.

Royal A1-P	Voltage, current and frequency measurement.
Royal A2-P	Three current measurement.
Royal A3-P	Three voltage measurement.
Royal A4-P	Single phase or three phase system measurement.
Royal A5-P	Three current measurement for engines protection.
DH96 D.C. —	Programmable digital meter d.c.
DH96 A.C. ~	Programmable digital meter a.c.
DH96 BG	Digital meters for electroplates baths (A / hour - A / minute).
DH96 CPM	Measurement D.C. Parameters (V - I - P - E).
DH96 FT	Frequency and r.p.m. Digital meter.
DH96 CT	Counting drive and Chronometer.

SELECTION GUIDE

	DH96 D.C.	DH96 A.C.	DH96 BG.	DH96 CPM	DH96 FT	DH96 CT	ROYAL A1	ROYAL A2	ROYAL A3	ROYAL A4	ROYAL A5
V D.C.	■	■	■	■	■	■	■	■	■	■	■
A D.C.	■	■	■	■	■	■	■	■	■	■	■
V A.C. ^{TRUE RMS}	■	■	■	■	■	■	■	■	■	■	■
A A.C. ^{TRUE RMS}	■	■	■	■	■	■	■	■	■	■	■
Hz	■	■	■	■	■	■	■	■	■	■	■
W ^{4 QUADRANTS}	■	■	■	■	■	■	■	■	■	■	■
Var ^{4 QUADRANTS}	■	■	■	■	■	■	■	■	■	■	■
VA ^{4 QUADRANTS}	■	■	■	■	■	■	■	■	■	■	■
PF ^{4 QUADRANTS}	■	■	■	■	■	■	■	■	■	■	■
Distorsion factor d^2	■	■	■	■	■	■	■	■	■	■	■
Max. demand Amperes	■	■	■	■	■	■	■	■	■	■	■
Max. demand Watts	■	■	■	■	■	■	■	■	■	■	■
3-V.A.C. ^{TRUE RMS}	■	■	■	■	■	■	■	■	■	■	■
3-A.A.C. ^{TRUE RMS}	■	■	■	■	■	■	■	■	■	■	■
DESEQUILIBRIO DE CORRIENTE	■	■	■	■	■	■	■	■	■	■	■
Ampar / h Ampar / min	■	■	■	■	■	■	■	■	■	■	■
KW - KW/h	■	■	■	■	■	■	■	■	■	■	■
Hz - r.p.m.	■	■	■	■	■	■	■	■	■	■	■
Count. pulses Chronometer	■	■	■	■	■	■	■	■	■	■	■

OPTIONAL CARDS

	DH96 D.C.	DH96 A.C.	DH96 BG.	DH96 CPM	DH96 FT	DH96 CT
2 RELAYS	■	■	■	■	■	■
4 RELAYS	■	■	■	■	■	■
ANALOG OUTPUT	■	■	■	■	■	■
RS-485 OUTPUT	■	■	■	■	■	■
RS-232 OUTPUT	■	■	■	■	■	■
2 RELAYS + ANALOG OUTPUT	■	■	■	■	■	■

NOTE :

Equipment's serie ROYAL have included 2 change over contact relays

